

Pro 700 Intercom system for Operating Theatre

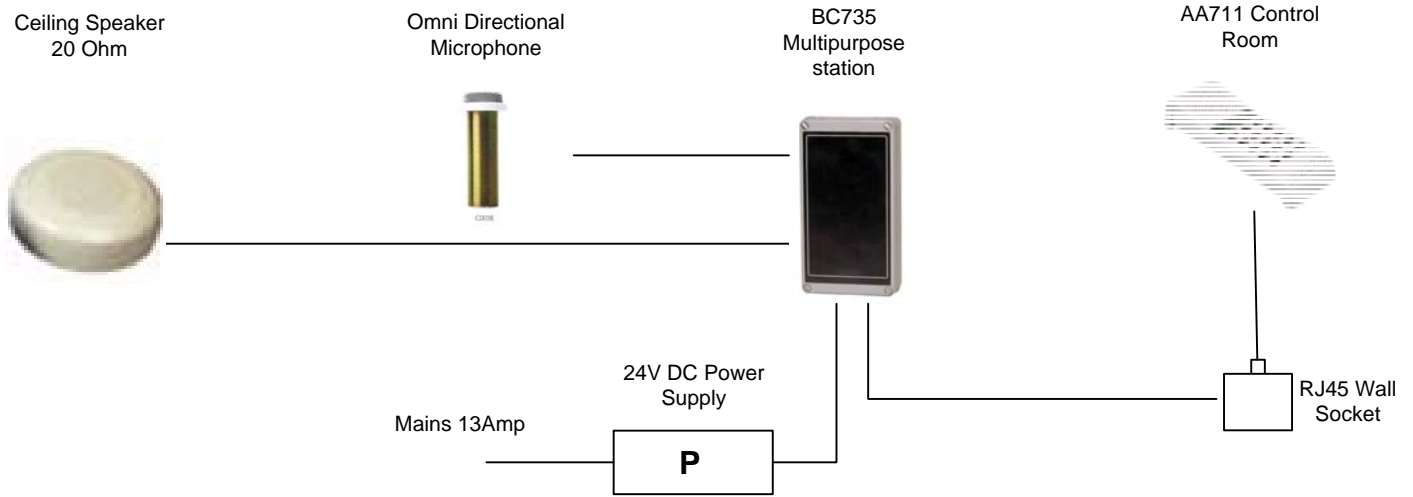

Connections for stations

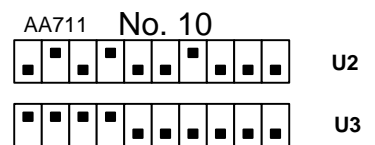
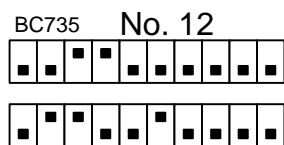
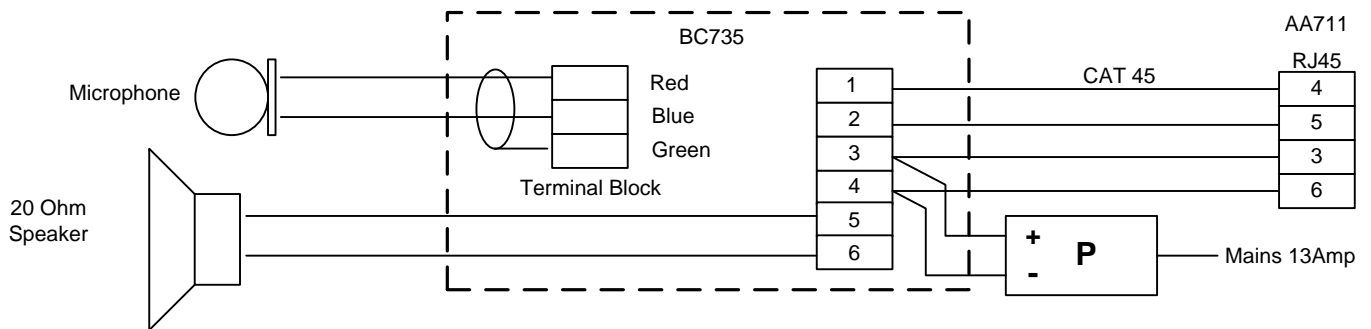

Installation

AA711 should be mounted with easy access for pressing "X"
 BC735 can be mounted in the control room or theatre.
 Cable between AA711 and BC735 is CAT5 cable
 Cable for microphone should be microphone cable
 The speaker requires 2 core speaker cable

Recommendations

Microphone must be fitted where it can pickup speech and not equipment noise.
 Loudspeaker can be fitted to ceiling tile or on the wall above viewing window.
 Loudspeaker and Microphone must be spaced so that there is no Feedback. Approx 1 mtr
 Recommend speaker not pointing at microphone.

One-Way Communications

To listen to the theatre dial "95 12 0" on the control room intercom, in this mode you will hear what is happening in the theatre. Hold the "T" button to talk to the theatre. This is one-way communication, let go of the "T" button to return to listen.

Two-Way Communication

For a two-way communication, dial "12" this will be two-way communications, with the loudest wins. The "T" key on Control room station will allow you to talk over noise from other station.

Close System

To cancel all communications (Switch OFF) press "X"