

TAMPER RESISTANT SUBSTATION



when communication is **critical**

FEATURES

- **Extremely rugged metal front plate of anodized brushed aluminium, 6 mm**
- **No-penetration speaker grille. Protected microphone and amplifier**
- **Red "microphone open" LED**
- **Built-in 45 Ohm loudspeaker**
- **Excellent sensitivity and voice reproduction**
- **Adjustable microphone sensitivity**
- **Screw terminals for easy connection of installation cables**
- **Freely programmable extension numbers or features**
- **Securely fastened**



DESCRIPTION

This Tamper-Resistant Substation has an extremely rugged metal front plate of anodized, brushed aluminium. The substation has a unique design to protect the loudspeaker, microphone, LED indicator and internal electronics from external abuse. The station flush-mounts on a back box. The metal front plate can be securely fastened to the box with 4mm tamper resistant screws (provided) or pop rivets.

Fast call initiation is possible with the call-in button. Call-in can be programmed to call any extension number or feature - including Emergency Calls, All Calls - or call queuing to a STENTOFON Control Room Master (CRM), MLH, or Call Handler System. The station has a built-in 45 Ohm loudspeaker. With a potentiometer located inside the casing, it is possible to adjust the microphone sensitivity according to the environmental conditions. The station has screw terminals with labels ensuring easy installation.

SPECIFICATIONS

Order Number	1070601010
Operating Voltage	Powered from exchange
Cable Requirements	2 pair 0.5 mm ² / 24 AWG twisted cable
Temperature Range	+10°C to +40°C, +50°F to +104°F
Non-Condensing Humidity	10% - 85% RH
Dimensions:(H x W x D)	140 x 190 x 63 mm, 5.5" x 7.5" x 2.5"
Weight	1 kg / 2.2 lb
Finish	Frontplate: 6 mm machined, anodized brushed aluminium
Max. Loudspeaker Output	1.4 W / 45 Ohm
Loudspeaker Impedance	45 Ohm

ORDER NUMBER	DESCRIPTION	SHIP WEIGHT
1070601010	TamperResistant Substation withCall button	1.15 kg / 2.53 lb
Supplementary equipment: 1000629700	FlushMountBack Box (4 mm screw threading)	0.7 kg / 1.5 lb
1000629800	Back Box, On WallMount	

TAMPER RESISTANT SUBSTATION

FrequencyRange	300 - 5000 Hz (±15 dB)
SoundPressure at 1m: Internal Loudspeaker	68 dB (0.5 mm cable x 100 m, 2.5 V on subscriber board , 1 kHz)
Connector Type	Screw terminals
Indicator	LED (red)

INSTALLATION

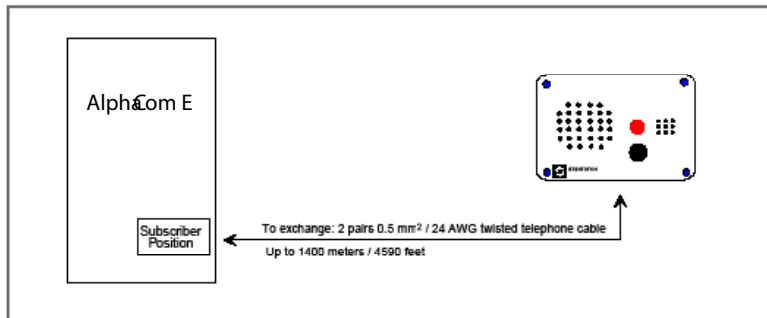

WIRING

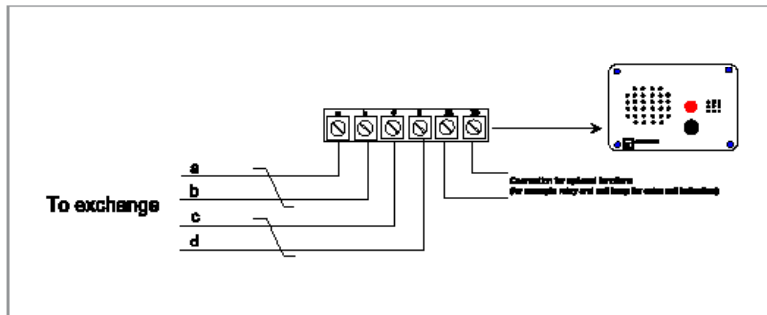

BACK BOX - FLUSH MOUNT

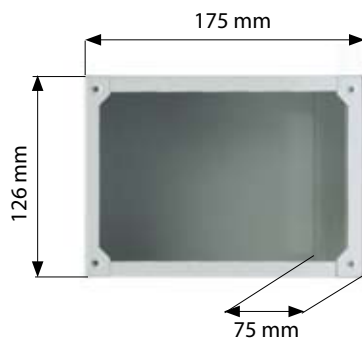

BACK BOX - ONWALLMOUNT

